

Current Sensor

Product Series: STK-BS/S

Part number: STK-50BS/S, STK-100BS/S
STK-200BS/S, STK-300BS/S
STK-400BS/S, STK-500BS/S
STK-600BS/S

Version: Ver 2.5



CONTENT

1.	Description	2
2.	Electrical data	3
3.	Dimension & Pin definitions.....	4

深圳市优博尔科技

1. Description

The STK-BS/S series current sensor is based on TMR (tunnel magnetoresistance) technology and open-loop design. It is suitable for DC, AC pulsed and any kind of irregular current measurement under the isolated conditions.

Typical applications

- AC Variable speed drives
- Electric welder power supply
- Inverter
- Switched model power supplies (SMPS)

General parameter

Parameter	Symbol	Unit	Value
Working temperature	T_A	°C	-40 ~ 105
Storage temperature	T_stg	°C	-40 ~ 105
Mass	m	g	40

Absolute maximum rating

Parameter	Symbol	Unit	Value
Supply voltage	Vcc	V	6.5
ESD rating (HBM)	U_ESD	kV	4

Remark: the unrecoverable damage may occur when the product works on the conditions over the absolute maximum ratings. Long-time working on the absolute maximum ratings may cause the degradation on performance and reliability.

Isolation parameter

Parameter	Symbol	Unit	Value	Comment
RMS voltage for AC test 50Hz/1 min	Ud	kV	4	
Clearance distance (pri. -sec)	dCl	mm	8	Shortest distance through air
Creepage distance (pri. -sec)	dCp	mm	8	Shortest path along device body
Case material			V0 according to UL 94	

Measuring current table

Product	Nominal RMS current	Measuring range
STK-50BS/S	50 A	150 A
STK-100BS/S	100 A	300 A
STK-200BS/S	200 A	600 A
STK-300BS/S	300 A	900 A
STK-400BS/S	400 A	1100 A
STK-500BS/S	500 A	1100 A
STK-600BS/S	600 A	1100 A

2. Electrical data

Condition: $T_A = 25^\circ\text{C}$, $V_{cc} = 5\text{ V}$

Parameter	Symbol	Unit	Min	Typ	Max	Comment
Primary nominal current rms	I_{PN}	A		50		STK-50BS/S
				100		STK-100BS/S
				200		STK-200BS/S
				300		STK-300BS/S
				400		STK-400BS/S
				500		STK-500BS/S
				600		STK-600BS/S
Primary current measuring range	I_{PM}	A	-150		150	STK-50BS/S
			-300		300	STK-100BS/S
			-600		600	STK-200BS/S
			-900		900	STK-300BS/S
			-1100		1100	STK-400BS/S
			-1100		1100	STK-500BS/S
			-1100		1100	STK-600BS/S
Supply voltage	V_{cc}	V	4.75	5	5.25	
Current consumption	I_{cc}	mA		20		
Rated output voltage	V_{FS}	V		± 0.625		($V_{out} @ \pm I_{PN}$) – V_{off}
Internal output resistance	R_{out}	Ω		2		V_{out}
Reference output resistance	R_{ref}	Ω		2		V_{ref}
Quiescent voltage	V_{off}	V	2.475	2.5	2.525	$V_{out} @ 0\text{ A}$
Reference voltage	V_{ref}	V	2.475	2.5	2.525	Output function
Electrical offset voltage	V_{oe}	V		$V_{ref} \pm 0.015$		$T_A @ 25^\circ\text{C}$
Theoretical gain	G_{th}	mV/A		12.5		STK-50BS/S
				6.25		STK-100BS/S
				3.125		STK-200BS/S
				2.08		STK-300BS/S
				1.56		STK-400BS/S
				1.25		STK-500BS/S
				1.04		STK-600BS/S
Rated linearity error	Non-L	% I_{PN}		± 1		$\pm I_{PN}$
Reaction time	t_{ra}	μs		1		@ 10% of I_{PM}
Step response time	t_{res}	μs		2.5		@ 90% of I_{PM}
Delay time	t_{delay}	μs		1.5		250 kHz sine

						wave
Frequency bandwidth (-3dB)	BW	kHz		250		No RC circuit
Output voltage noise DC ~ 10 kHz	Vnoise	mVpp		30		
DC ~ 100 kHz				40		
Accuracy @ 25°C	X	% of I _{PN}		±1		@ 25°C
Accuracy @ -40°C~105°C	X_TRange	% of I _{PN}	-3.5		3.5	-40°C ~ 105°C

3. Dimension & Pin definitions

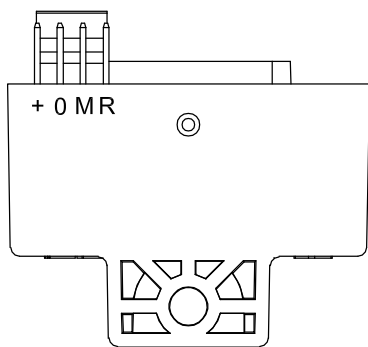
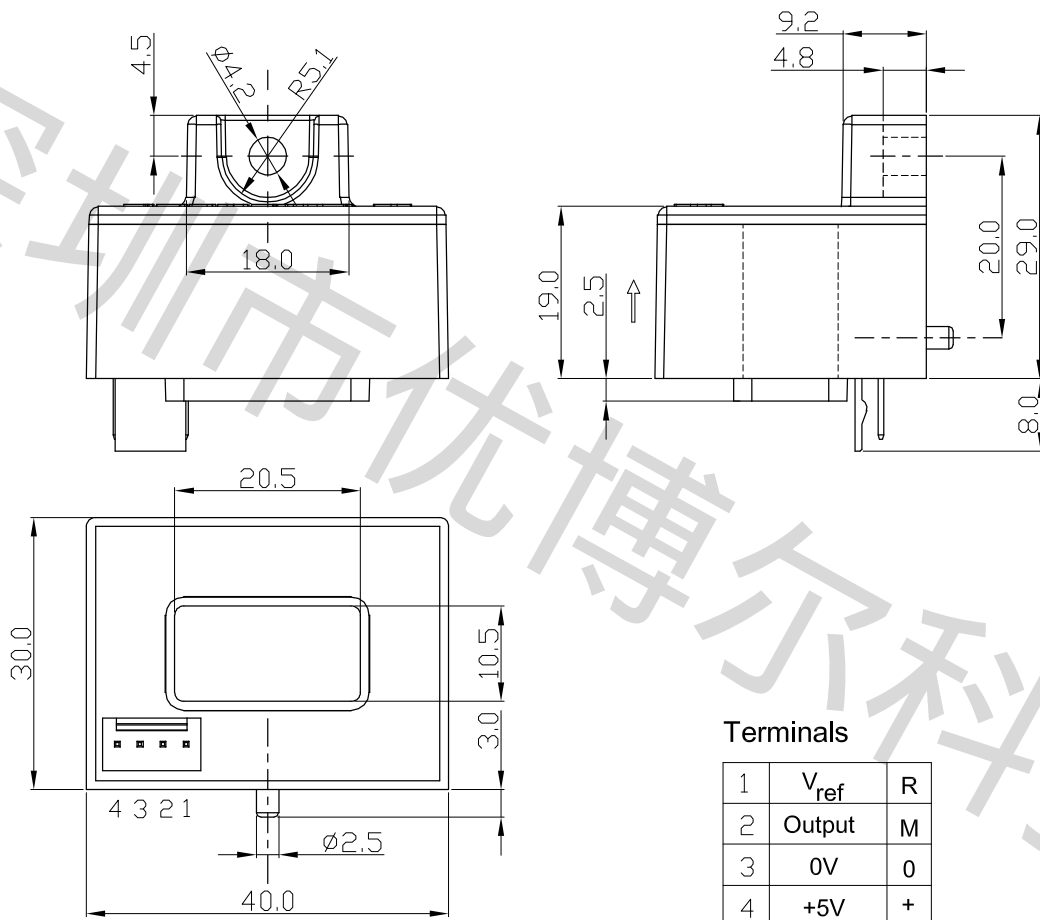

Material : Fit UL94V-0 & RoHS requirements ;
 General tolerance : ±0.5
 Unit :mm

